

The VISOR® Code Reader reads whatever's printed, dot peened and lasered.

System description

With its integrated object detection, the VISOR® Code Reader is unique in its price segment. The compact sensor reads conventional 1D bar codes, 2D data matrix codes and now also optical characters (OCR). It also has four detectors for object detection (pattern comparison, brightness, grey level and contrast), with which other object features – for example, stamps or logos – can be evaluated in a single reading pass. Codes and object features are even reliably detected with deviations from the taught-in position – using position tracking (optionally activated).

A special image filter with expanded setting options guarantees excellent reading performance even under difficult reading conditions. The test results can largely be evaluated within the sensor itself – with the option of string comparison or regular print-outs – so that there is no need for a PLC or PC connection in many cases. If, however, this proves necessary, it can be easily and flexibly connected using freely available PLC function blocks for Siemens S7, Codesys and Allen Bradley.

With integrated quality parameters complying with ISO and AIM standards, the VISOR® Code Reader also permits the informative evaluation of printed and directly marked 1D and 2D codes. Integrated red, infrared or white light variants provide maximum functional reliability through optimum code illumination.

In addition, the robust, compact and industry-oriented housings guarantee reliability even where space is restricted. Integrated 6 mm or 12 mm optics or C-mount devices also save effort and costs through their optimum adaptation to the most varied of code sizes and operating distances. The new V20 variants also offer a resolution of 1.3 megapixels for particularly small codes or large search areas.

VISOR® Code Reader product variants

Features/sensors	Standard	Advanced	Professional
Functions			
V10 resolution in pixels	736 x 480	736 x 480	–
V20 resolution in pixels	–	1280 x 1024	1280 x 1024
Image rate per second V10 V20	50 –	50 40	– 40
Number of jobs detectors	8 2	max. 255 max. 255	max. 255 max. 255
Position tracking	–	✓	✓
Pattern comparison (X-, Y-translation)	–	✓	✓
Grey threshold	–	✓	✓
Contrast	–	✓	✓
Brightness	–	✓	✓
Data code	✓	✓	✓
Bar code	✓	✓	✓
OCR	–	–	✓
Freeform Tool	–	✓	✓
		(not with data codes and bar codes)	(not with data codes, bar codes and OCR)
Interfaces			
Inputs outputs	2 4	2 4	2 4
Freely definable switching outputs/inputs, PNP or NPN	2	4	4
Encoder input	–	✓	✓
I/O expansion	✓	✓	✓
RS422 RS232	✓ ✓	✓ ✓	✓ ✓
Ethernet / data transmission	✓	✓	✓
EtherNet / IP	✓	✓	✓
PROFINET	✓	✓	✓
Lens			
V10: integrated 6 mm 12 mm 25 mm	✓ ✓ –	✓ ✓ ✓	–
V20: integrated 12 mm	–	✓	✓
C-mount	–	✓	✓
Operation / visualisation			
Viewer software with user guidance	✓	✓	✓
Hierarchised user rights	✓	✓	✓

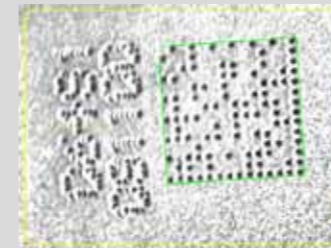

Dot peened code on rough substrate
Code is made legible by powerful reading algorithm. Presence of the nailed imprint in plain text can be checked using object detection.



Low-contrast code
Code is made legible through high tolerance – also towards weakly contrasting codes.



Optical character reading
Dot matrix printing can also be read with OCR

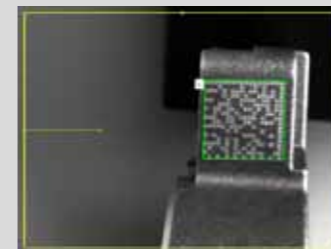

Code with small "quiet zone"
Even codes with a small quiet zone or damaged finder pattern can be read.

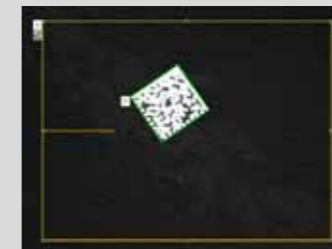

Code reading on solar cells
Even extremely small codes (e.g. on silicon solar cells) or highly reflective codes (e.g. on thin-layer solar cells) can be read.



Printed codes on pharmaceutical packaging
ECC200 or bar codes (e.g. EAN 13) can be searched for simultaneously. In addition to code reading, the presence of optical characters can also be checked using object detection.

Special features of the VISOR® Code Reader

- Can be used for all common 2D codes (e.g. ECC 200 data matrix) and common 1D bar codes
- Optimum cost-effectiveness through combination of two functions in one device: code reading and object detection
- High operating dependability through reliable detection of even poorly readable codes under difficult ambient conditions
- Flexible and simple connection to PC and PLC environments due to comprehensive possibilities for archiving pictures and read results, as well as freely available PLC function blocks for Siemens S7, Codesys and Allen Bradley
- Very high flexibility, e.g. also due to reading several similar or different codes in one reading pass
- Reading of optical characters with OCR based on neuronal networks, particularly suitable for point printing

Advanced vision sensor for code reading with object detection, 12 mm



PRODUCT HIGHLIGHTS

- Can be used for all common 2D codes (ECC 200 data matrix) and common 1D bar codes
- Combination of two functions in one device: code reading and object detection
- Reliable detection of even poorly readable codes under difficult ambient conditions
- Comprehensive tools for flexible and easy connection to PC and PLC environments
- Reading of several similar or differing types of codes in one reading pass

Optical data		Functions	
Resolution	1280 x 1024 pixels	Number of jobs / detectors	max. 255 / max. 255
CMOS	1/1.8", monochrome	Detectors	Pattern comparison, contrast, brightness, grey level, bar code, data code
Integrated lens, focal length	12 mm, adjustable focal position	Properties	X/Y position tracking; pattern comparison: teach-in and pattern detection; grey level, brightness: evaluation of brightness; contrast: evaluation of contrast; bar code: reading of 1D bar codes, EAN, UPC, RSS, 2/5 Interleaved, 2/5 Industrial, Code 39, Code 93, Code 128, GS1, Pharmacode, Codabar; data code: reading of 2D codes: ECC200, QR code, PDF 417
Adjustment range	30 mm to infinity	Typical cycle time ²	Typ. 20 ms pattern comparison; typ. 2 ms brightness; typ. 2 ms contrast; typ. 2 ms grey level; typ. 30 ms bar code; typ. 40 ms data code
Integrated illumination	White, red, infrared, UV (400 nm) LEDs		
Minimum field of view, X x Y	16 x 13 mm ²		
Electrical data		Mechanical data	
Operating voltage, +U _B	18 ... 26.4 V DC ¹	Dimensions	65 x 45 x 45 mm ³ (without plug)
Current consumption (without illumination and I/O)	≤ 120 mA	Enclosure rating	IP 67
Current consumption (without I/O)	≤ 200 mA	Material, housing	Aluminium, plastic
Protective circuits	Reverse-polarity protection, U _B / short-circuit protection of all outputs	Material, front screen	Plastic
Power On Delay	Ca. 13 s after Power on	Ambient temperature: operation	0 ... +50 °C ³
Outputs	PNP / NPN (switchable)	Ambient temperature: storage	-20 ... +60 °C ³
Max. output current (per output)	50 mA, 100 mA (pin 12)	Weight	Ca. 160 g
Inputs	PNP/NPN High > U _B -1 V, Low < 3 V	Plug connection	Power and I/O M12 12-pin Ethernet M12 4-pin Data M12 5-pin
Input resistance	> 20 kΩ	Vibration and impact resistance	EN 60947-5-2
Encoder input	High > 4 V		
Interfaces	Ethernet (LAN), RS422, RS232, EtherNet/IP, PROFINET		
Inputs/outputs	2 inputs, 4 outputs, 4 selectable inputs/outputs		

¹ Max. ripple < 5V_{SS} ² with VGA-resolution (640 x 480 pixels) ³ 80 % air humidity, non-condensing

Illumination	Part number	Article number
White	V20-CR-A2-W12	536-91001
Red	V20-CR-A2-R12	536-91002
Infrared	V20-CR-A2-I12	536-91003
UV (400 nm)	V20-CR-A2-U12	536-91019

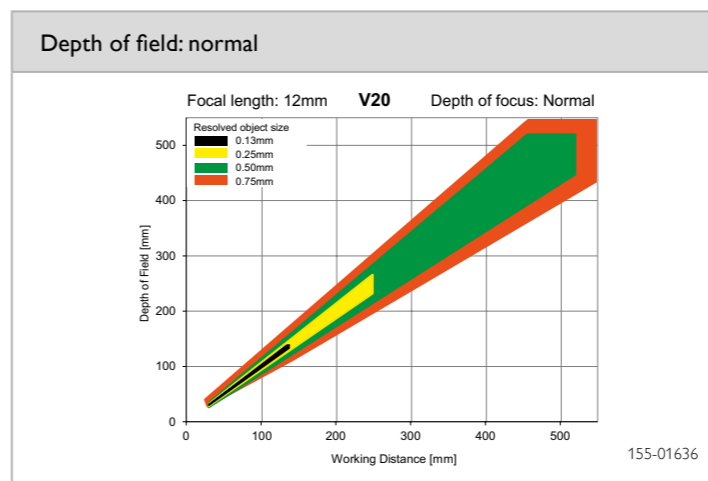
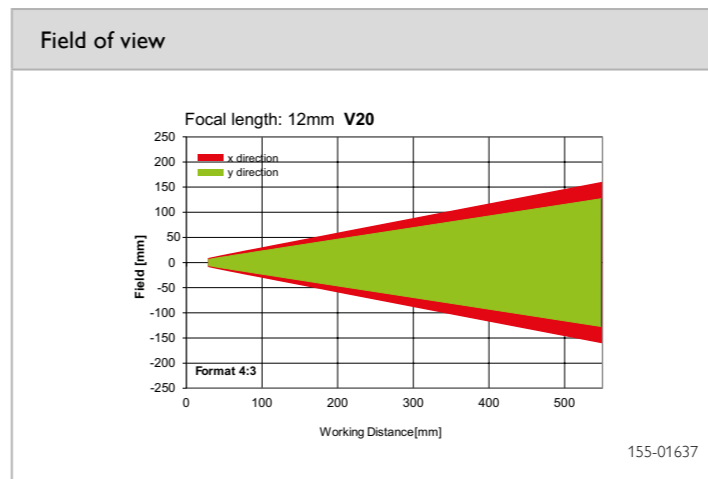
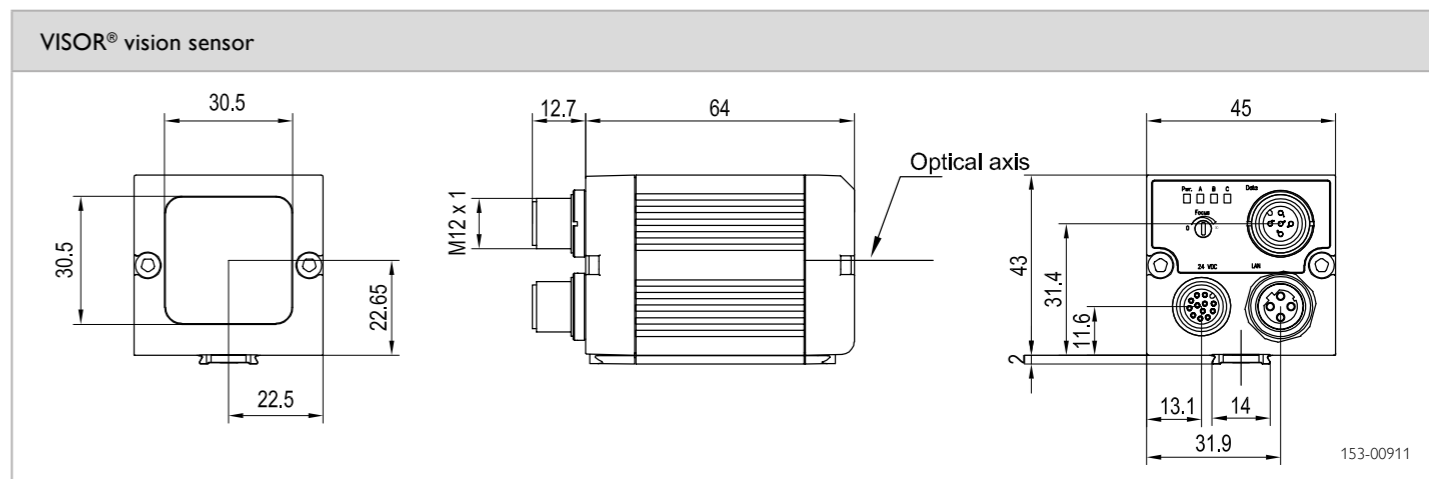

Accessories	
Connection cables	From Page A-32
Illumination	From Page A-25
Brackets	From Page A-4
Interface accessories	From Page A-36

Advanced vision sensor for code reading with object detection, 12 mm



PRODUCT HIGHLIGHTS

- Can be used for all common 2D codes (ECC 200 data matrix) and common 1D bar codes
- Code reading of colour image
- Reliable detection of even poorly readable codes under difficult ambient conditions
- Comprehensive tools for flexible and easy connection to PC and PLC environments
- Reading of several similar or differing types of codes in one reading pass

Optical data		Functions	
Resolution	1280 x 1024 pixels	Number of jobs / detectors	max. 255 / max. 255
CMOS	1/1.8", colour	Detectors	Pattern comparison, contrast, brightness, grey level, bar code, data code
Integrated lens, focal length	12 mm, adjustable focal position	Properties	X/Y position tracking; pattern comparison: teach-in and pattern detection; grey level, brightness: evaluation of brightness; contrast: evaluation of contrast; bar code: reading of 1D bar codes, EAN, UPC, RSS, 2/5 Interleaved, 2/5 Industrial, Code 39, Code 93, Code 128, GS1, Pharmacode, Codabar; data code: reading of 2D codes: ECC200, QR code, PDF 417
Adjustment range	30 mm to infinity	Typical cycle time ²	Typ. 20 ms pattern comparison; typ. 2 ms brightness; typ. 2 ms contrast; typ. 2 ms grey level; typ. 30 ms bar code; typ. 40 ms data code
Integrated illumination	White LEDs		
Minimum field of view, X x Y	16 x 13 mm ²		
Electrical data		Mechanical data	
Operating voltage, +U _B	18 ... 26.4 V DC ¹	Dimensions	65 x 45 x 45 mm ³ (without plug)
Current consumption (without illumination and I/O)	≤ 120 mA	Enclosure rating	IP 67
Current consumption (without I/O)	≤ 200 mA	Material, housing	Aluminium, plastic
Protective circuits	Reverse-polarity protection, U _B / short-circuit protection of all outputs	Material, front screen	Plastic
Power On Delay	Ca. 13 s after Power on	Ambient temperature: operation	0 ... +50 °C ³
Outputs	PNP / NPN (switchable)	Ambient temperature: storage	-20 ... +60 °C ³
Max. output current (per output)	50 mA, 100 mA (pin 12)	Weight	Ca. 160 g
Inputs	PNP/NPN High > U _B -1 V, Low < 3 V	Plug connection	Power and I/O M12 12-pin Ethernet M12 4-pin Data M12 5-pin
Input resistance	> 20 kΩ	Vibration and impact resistance	EN 60947-5-2
Encoder input	High > 4 V		
Interfaces	Ethernet (LAN), RS422, RS232, EtherNet/IP, PROFIBUS		
Inputs/outputs	2 inputs, 4 outputs, 4 selectable inputs/outputs		

¹ Max. ripple < 5V_{SS} ² with VGA-resolution (640 x 480 pixels) ³ 80 % air humidity, non-condensing

Illumination	Part number	Article number
White	V20C-CR-A2-W12	536-91026

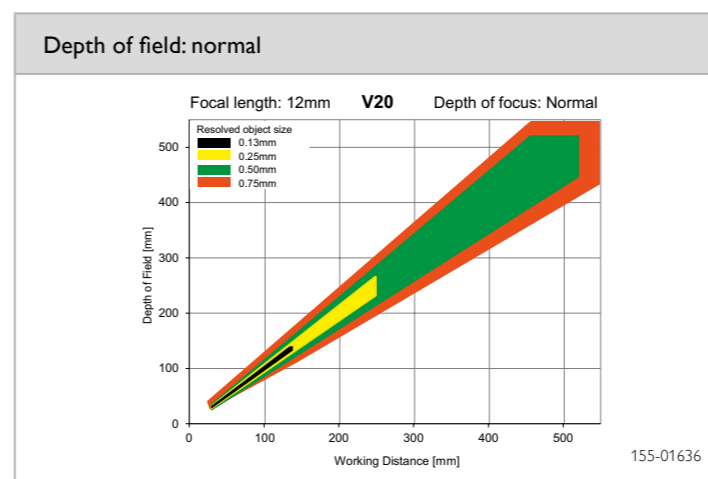
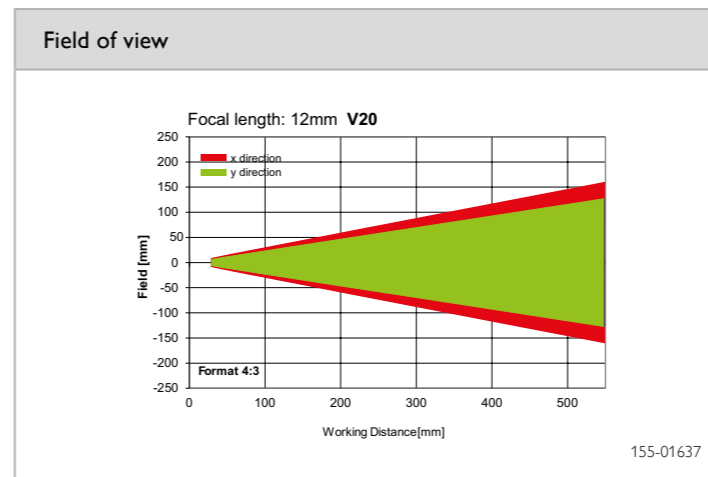
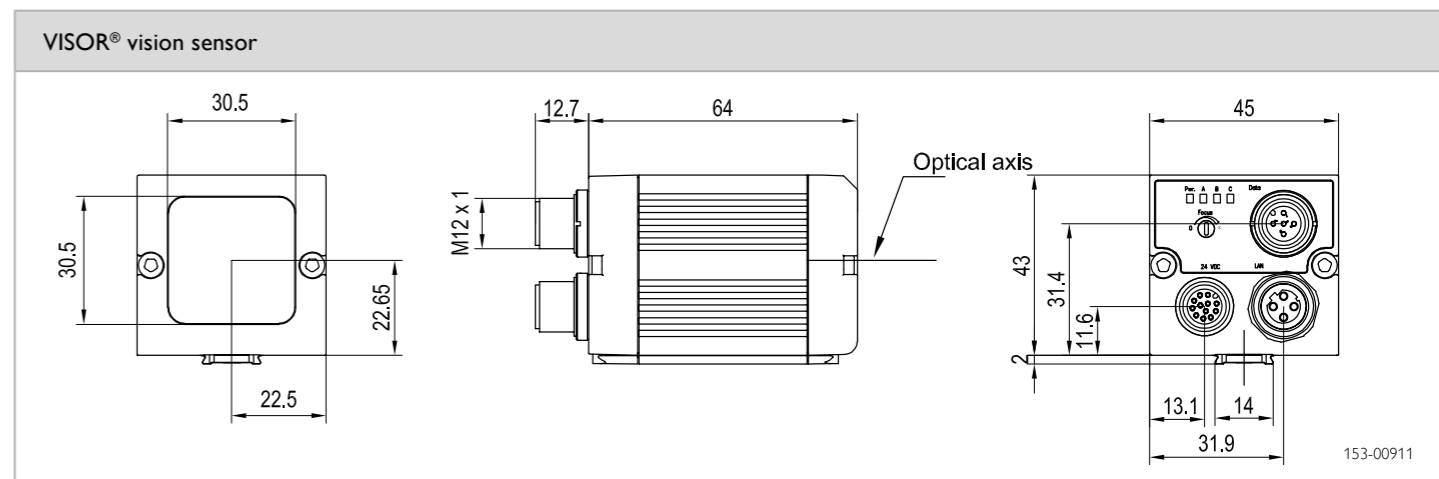

Accessories	
Connection cables	From Page A-32
Illumination	From Page A-25
Brackets	From Page A-4
Interface accessories	From Page A-36

Advanced vision sensor for code reading with object detection, C-mount



PRODUCT HIGHLIGHTS

- Can be used for all common 2D codes (ECC 200 data matrix) and common 1D bar codes
- Combination of two functions in one device: code reading and object detection
- Reliable detection of even poorly readable codes under difficult ambient conditions
- Comprehensive tools for flexible and easy connection to PC and PLC environments
- Reading of several similar or differing types of codes in one reading pass

Optical data		Functions	
Resolution	1280 x 1024 pixels	Number of jobs / detectors	max. 255 / max. 255
CMOS	1/1.8", monochrome	Detectors	Pattern comparison, contrast, brightness, grey level, bar code, data code
Integrated lens, focal length	C-mount	Properties	X/Y position tracking; pattern comparison: teach-in and pattern detection; grey level, brightness: evaluation of brightness; contrast: evaluation of contrast; bar code: reading of 1D bar codes, EAN, UPC, RSS, 2/5 Interleaved, 2/5 Industrial, Code 39, Code 93, Code 128, GS1, Pharmacode, Codabar; data code: reading of 2D codes: ECC200, QR code, PDF 417
Adjustment range	Dependent on lens	Typical cycle time ²	Typ. 20 ms pattern comparison; typ. 2 ms brightness; typ. 2 ms contrast; typ. 2 ms grey level; typ. 30 ms bar code; typ. 40 ms data code
Integrated illumination	None		
Minimum field of view, X x Y	Dependent on lens		
Electrical data		Mechanical data	
Operating voltage, +U _B	18 ... 26.4 V DC ¹	Dimensions	65 x 45 x 45 mm ³ (without plug)
Current consumption (without illumination and I/O)	≤ 120 mA	Enclosure rating	IP 65 ³
Current consumption (without I/O)	≤ 200 mA	Material, housing	Aluminium, plastic
Protective circuits	Reverse-polarity protection, U _B / short-circuit protection of all outputs	Material, front screen	Plastic
Power On Delay	Ca. 13 s after Power on	Ambient temperature: operation	0 ... +50 °C ⁴
Outputs	PNP / NPN (switchable)	Ambient temperature: storage	-20 ... +60 °C ⁴
Max. output current (per output)	50 mA, 100 mA (pin 12)	Weight	Ca. 160 g
Inputs	PNP/NPN High > U _B -1 V, Low < 3 V	Plug connection	Power and I/O M12 12-pin Ethernet M12 4-pin Data M12 5-pin
Input resistance	> 20 kΩ	Vibration and impact resistance	EN 60947-5-2
Encoder input	High > 4 V		
Interfaces	Ethernet (LAN), RS422, RS232, EtherNet/IP, PROFINET		
Inputs/outputs	2 inputs, 4 outputs, 4 selectable inputs/outputs		

¹ Max. ripple < 5V_{SS} ² With VGA-resolution (640 x 480 Pixel) ³ With LPT45 C-mount protective casing ⁴ 80 % air humidity, non-condensing

Part number	Article number
V20-CR-A2-C	536-91000

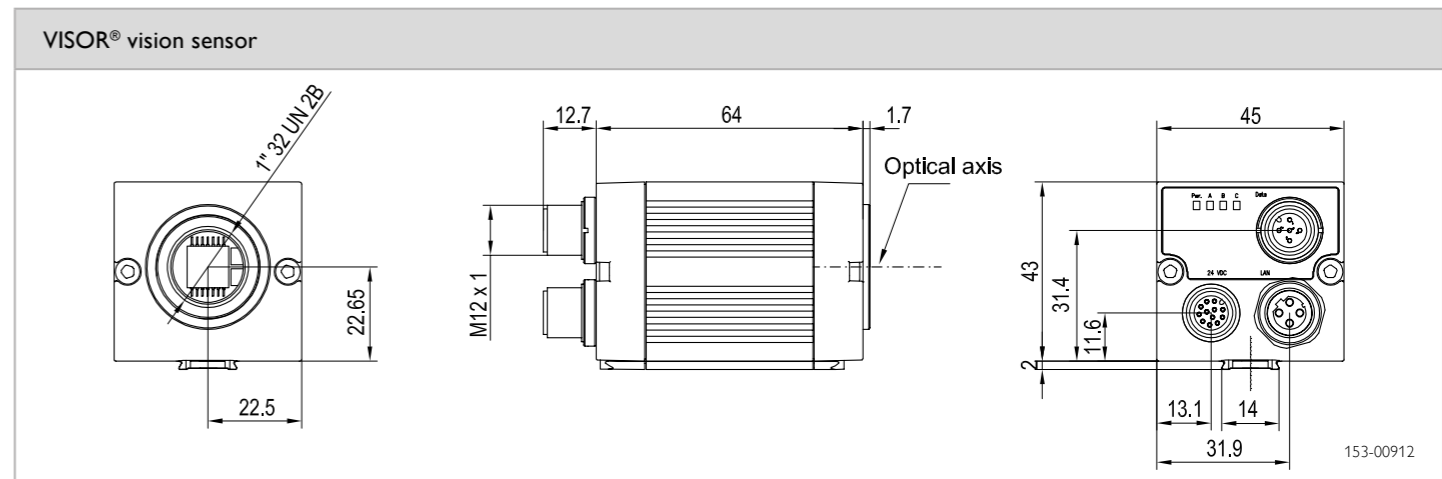

	LO C 8	LO C 12	LO C 16	LO C 25	LO C 35	LO C 50	LO C 75
Focal length	8 mm	12 mm	16 mm	25 mm	35 mm	50 mm	75 mm
Article number	526-51513	526-51514	526-51515	526-51516	526-51525	526-51113	526-51116

Accessories	
Connection cables	From Page A-32
Illumination	From Page A-25
Lenses	From Page A-23
Brackets	From Page A-4
Interface accessories	From Page A-36

Professional vision sensor for code reading, object detection and OCR, 12 mm

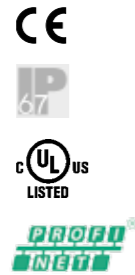

PRODUCT HIGHLIGHTS

- Can be used for all common 2D codes (ECC 200 data matrix) and common 1D bar codes
- Combination of two functions in one device: code reading and object detection
- Reliable detection of even poorly readable codes under difficult ambient conditions
- Comprehensive tools for flexible and easy connection to PC and PLC environments
- Reading of several similar or differing types of codes in one reading pass
- Reading of optical characters with OCR

Optical data		Functions	
Resolution	1280 x 1024 pixels	Number of jobs / detectors	max. 255 / max. 255
CMOS	1/1.8", monochrome	Detectors	Pattern comparison, contrast, brightness, grey level, bar code, data code, OCR
Integrated lens, focal length	12 mm, adjustable focal position	Properties	X/Y position tracking; pattern comparison: teach-in and pattern detection; grey level, brightness: evaluation of brightness; contrast: evaluation of contrast; bar code: reading of 1D bar codes, EAN, UPC, RSS, 2/5 Interleaved, 2/5 Industrial, Code 39, Code 93, Code 128, GS1, Pharmacode, Codabar; data code: reading of 2D codes: ECC200, QR code, PDF 417; OCR: optical character reading
Adjustment range	30 mm to infinity	Typical cycle time ²	Typ. 20 ms pattern comparison; typ. 2 ms brightness; typ. 2 ms contrast; typ. 2 ms grey level; typ. 30 ms bar code; typ. 40 ms data code; typ. 15 ms per character OCR
Integrated illumination	White, red, infrared LEDs		
Minimum field of view, X x Y	16 x 13 mm ²		
Electrical data		Mechanical data	
Operating voltage, +U _b	18 ... 26.4V DC ¹	Dimensions	65 x 45 x 45 mm ³ (without plug)
Current consumption (without illumination and I/O)	≤ 120 mA	Enclosure rating	IP 67
Current consumption (without I/O)	≤ 200 mA	Material, housing	Aluminium, plastic
Protective circuits	Reverse-polarity protection, U _b / short-circuit protection of all outputs	Material, front screen	Plastic
Power On Delay	Ca. 13 s after Power on	Ambient temperature: operation	0 ... +50 °C ³
Outputs	PNP / NPN (switchable)	Ambient temperature: storage	-20 ... +60 °C ³
Max. output current (per output)	50 mA, 100 mA (pin 12)	Weight	Ca. 160 g
Inputs	PNP/NPN High > U _b -1V, Low < 3V	Plug connection	Power and I/O M12 12-pin Ethernet M12 4-pin Data M12 5-pin
Input resistance	> 20 kΩ	Vibration and impact resistance	EN 60947-5-2
Encoder input	High > 4V		
Interfaces	Ethernet (LAN), RS422, RS232, EtherNet/IP, PROFINET		
Inputs/outputs	2 inputs, 4 outputs, 4 selectable inputs/outputs		

¹ Max. ripple < 5V_{ss} ² With VGA-resolution (640 x 480 Pixel) ³ 80 % air humidity, non-condensing

Illumination	Part number	Article number
White	V20-CR-P2-W12	536-91005
Red	V20-CR-P2-R12	536-91006
Infrared	V20-CR-P2-I12	536-91007

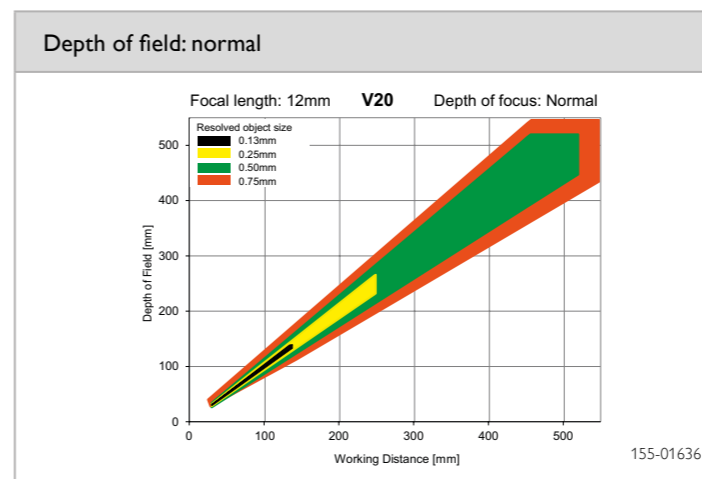
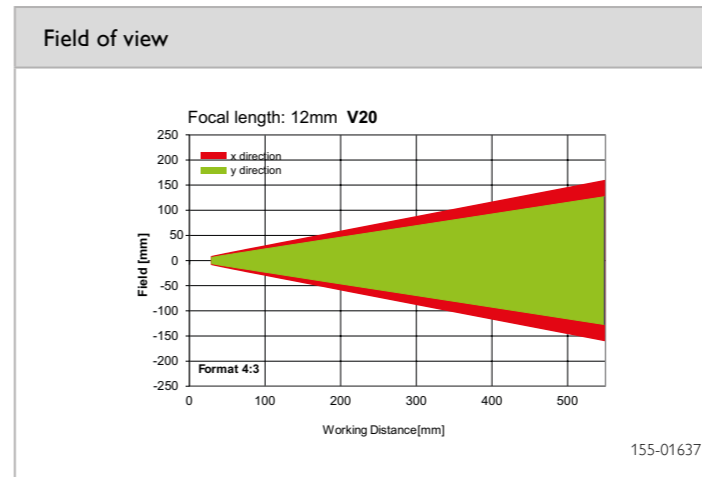
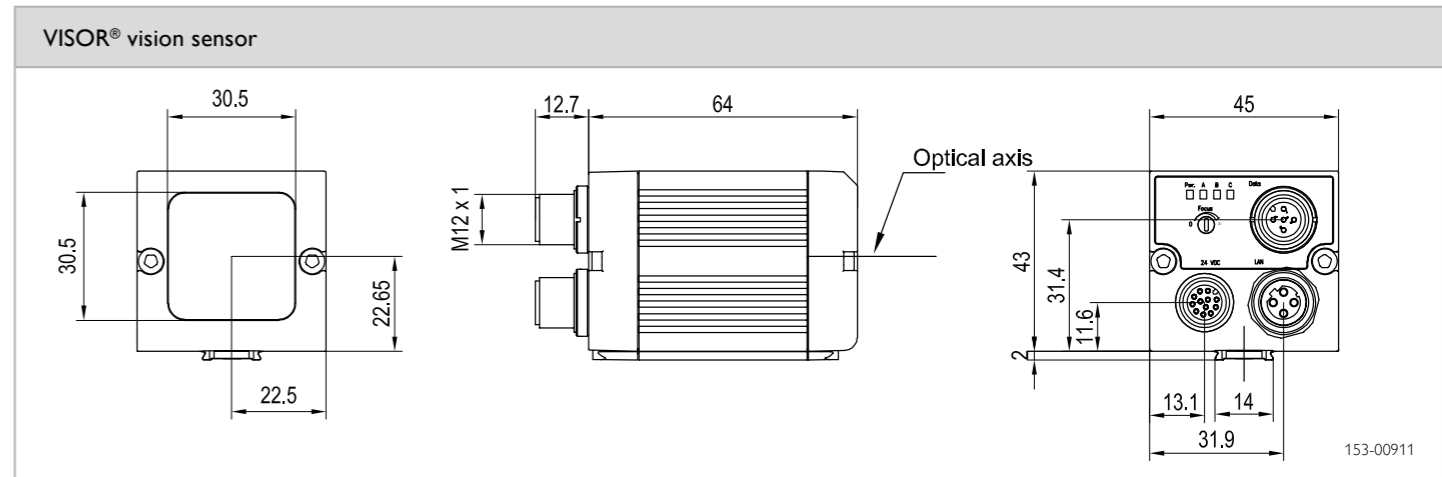

Accessories	
Connection cables	From Page A-32
Illumination	From Page A-25
Brackets	From Page A-4
Interface accessories	From Page A-36

Professional vision sensor for code reading, object detection and OCR, 12 mm



PRODUCT HIGHLIGHTS

- Can be used for all common 2D codes (ECC 200 data matrix) and common 1D bar codes
- Code reading of colour image
- Reliable detection of even poorly readable codes under difficult ambient conditions
- Comprehensive tools for flexible and easy connection to PC and PLC environments
- Reading of several similar or differing types of codes in one reading pass
- Reading of optical characters with OCR

Optical data		Functions	
Resolution	1280 x 1024 pixels	Number of jobs / detectors	max. 255 / max. 255
CMOS	1/1.8", colour	Detectors	Pattern comparison, contrast, brightness, grey level, bar code, data code, OCR
Integrated lens, focal length	12 mm, adjustable focal position	Properties	X/Y position tracking; pattern comparison: teach-in and pattern detection; grey level, brightness: evaluation of brightness; contrast: evaluation of contrast; bar code: reading of 1D bar codes, EAN, UPC, RSS, 2/5 Interleaved, 2/5 Industrial, Code 39, Code 93, Code 128, GS1, Pharmacode, Codabar; data code: reading of 2D codes: ECC200, QR code, PDF 417; OCR: optical character reading
Adjustment range	30 mm to infinity	Typical cycle time ²	Typ. 20 ms pattern comparison; typ. 2 ms brightness; typ. 2 ms contrast; typ. 2 ms grey level; typ. 30 ms bar code; typ. 40 ms data code; typ. 15 ms per character OCR
Integrated illumination	White, LEDs		
Minimum field of view, X x Y	16 x 13 mm ²		
Electrical data		Mechanical data	
Operating voltage, +U _b	18 ... 26.4V DC ¹	Dimensions	65 x 45 x 45 mm ³ (without plug)
Current consumption (without illumination and I/O)	≤ 120 mA	Enclosure rating	IP 67
Current consumption (without I/O)	≤ 200 mA	Material, housing	Aluminium, plastic
Protective circuits	Reverse-polarity protection, U _b / short-circuit protection of all outputs	Material, front screen	Plastic
Power On Delay	Ca. 13 s after Power on	Ambient temperature: operation	0 ... +50 °C ³
Outputs	PNP / NPN (switchable)	Ambient temperature: storage	-20 ... +60 °C ³
Max. output current (per output)	50 mA, 100 mA (pin 12)	Weight	Ca. 160 g
Inputs	PNP/NPN High > U _b -1V, Low < 3V	Plug connection	Power and I/O M12 12-pin Ethernet M12 4-pin Data M12 5-pin
Input resistance	> 20 kΩ	Vibration and impact resistance	EN 60947-5-2
Encoder input	High > 4V		
Interfaces	Ethernet (LAN), RS422, RS232, EtherNet/IP, PROFINET		
Inputs/outputs	2 inputs, 4 outputs, 4 selectable inputs/outputs		

¹ Max. ripple < 5V_{ss} ² With VGA-resolution (640 x 480 Pixel) ³ 80 % air humidity, non-condensing

Illumination	Part number	Article number
White	V20C-CR-P2-W12	536-91027

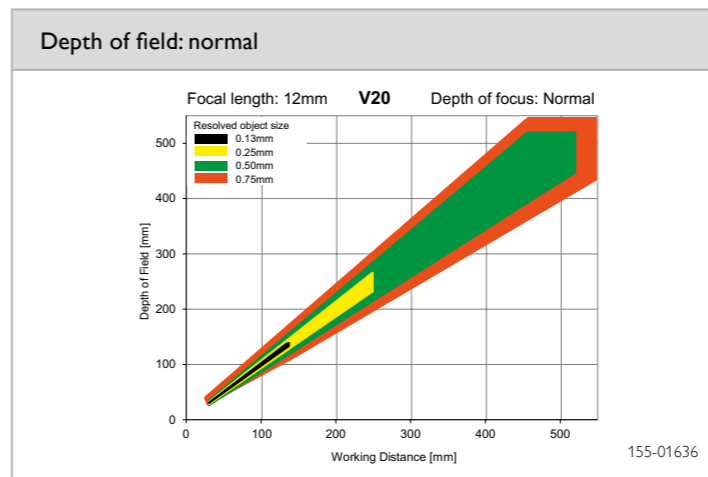
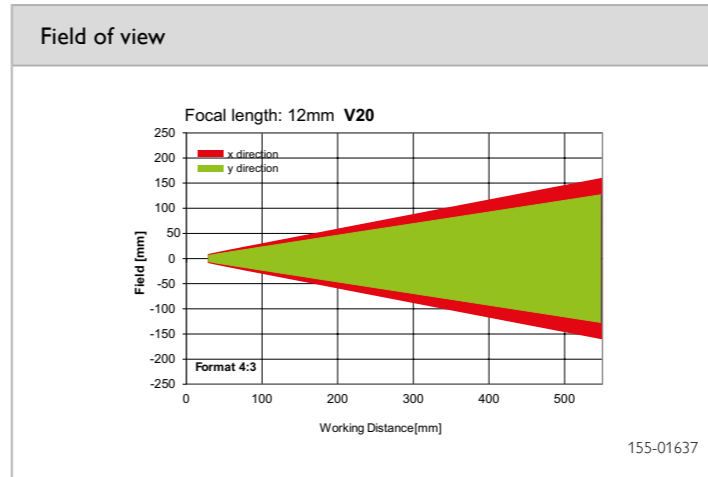
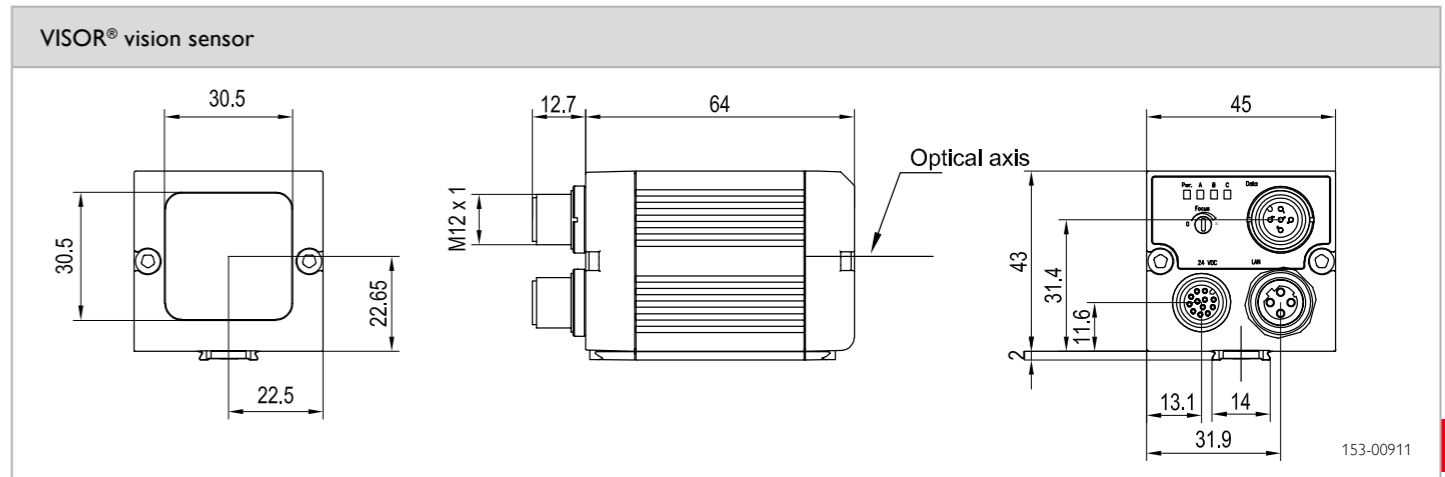

Accessories	
Connection cables	From Page A-32
Illumination	From Page A-25
Brackets	From Page A-4
Interface accessories	From Page A-36

Professional vision sensor for code reading, object detection and OCR, C-mount



PRODUCT HIGHLIGHTS

- Can be used for all common 2D codes (ECC 200 data matrix) and common 1D bar codes
- Combination of two functions in one device: code reading and object detection
- Reliable detection of even poorly readable codes under difficult ambient conditions
- Comprehensive tools for flexible and easy connection to PC and PLC environments
- Reading of several similar or differing types of codes in one reading pass
- Reading of optical characters with OCR

Optical data		Functions	
Resolution	1280 x 1024 pixels	Number of jobs / detectors	max. 255 / max. 255
CMOS	1/1.8", monochrome	Detectors	Pattern comparison, contrast, brightness, grey level, bar code, data code, OCR
Integrated lens, focal length	C-mount	Properties	X/Y position tracking; pattern comparison: teach-in and pattern detection; grey level, brightness: evaluation of brightness; contrast: evaluation of contrast; bar code: reading of 1D bar codes, EAN, UPC, RSS, 2/5 Interleaved, 2/5 Industrial, Code 39, Code 93, Code 128, GS1, Pharmacode, Codabar; data code: reading of 2D codes: ECC200, QR code, PDF 417; OCR: optical character reading
Adjustment range	Dependent on lens	Typical cycle time ²	Typ. 20 ms pattern comparison; typ. 2 ms brightness; typ. 2 ms contrast; typ. 2 ms grey level; typ. 30 ms bar code; typ. 40 ms data code; typ. 15 ms per character OCR
Integrated illumination	None		
Minimum field of view, X x Y	Dependent on lens		
Electrical data		Mechanical data	
Operating voltage, +U _b	18 ... 26.4V DC ¹	Dimensions	65 x 45 x 45 mm ³ (without plug)
Current consumption (without illumination and I/O)	≤ 120 mA	Enclosure rating	IP 65 ³
Current consumption (without I/O)	≤ 200 mA	Material, housing	Aluminium, plastic
Protective circuits	Reverse-polarity protection, U _b / short-circuit protection of all outputs	Material, front screen	Plastic
Power On Delay	Ca. 13 s after Power on	Ambient temperature: operation	0 ... +50 °C ⁴
Outputs	PNP / NPN (switchable)	Ambient temperature: storage	-20 ... +60 °C ⁴
Max. output current (per output)	50 mA, 100 mA (pin 12)	Weight	Ca. 160 g
Inputs	PNP/NPN High > U _b -1V, Low < 3V	Plug connection	Power and I/O M12 12-pin Ethernet M12 4-pin Data M12 5-pin
Input resistance	> 20 kΩ	Vibration and impact resistance	EN 60947-5-2
Encoder input	High > 4V		
Interfaces	Ethernet (LAN), RS422, RS232, EtherNet/IP, PROFINET		
Inputs/outputs	2 inputs, 4 outputs, 4 selectable inputs/outputs		

¹ Max. ripple < 5V_{ss} ² With VGA-resolution (640 x 480 Pixel) ³ With LPT45 C-mount protective casing ⁴ 80 % air humidity, non-condensing

Part number	Article number
V20-CR-P2-C	536-91004

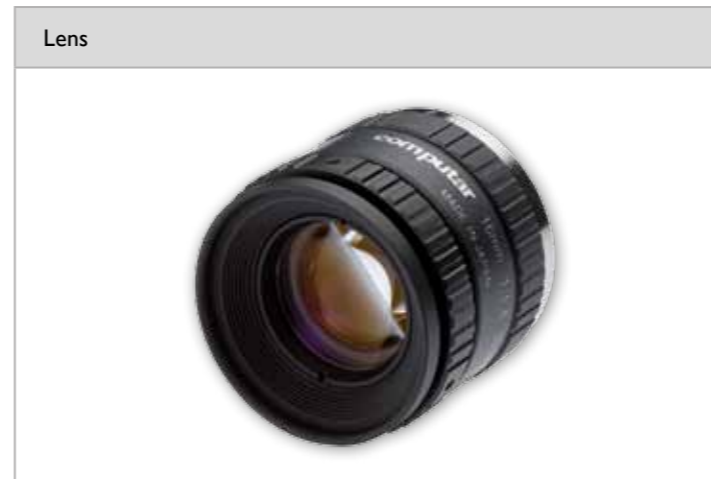
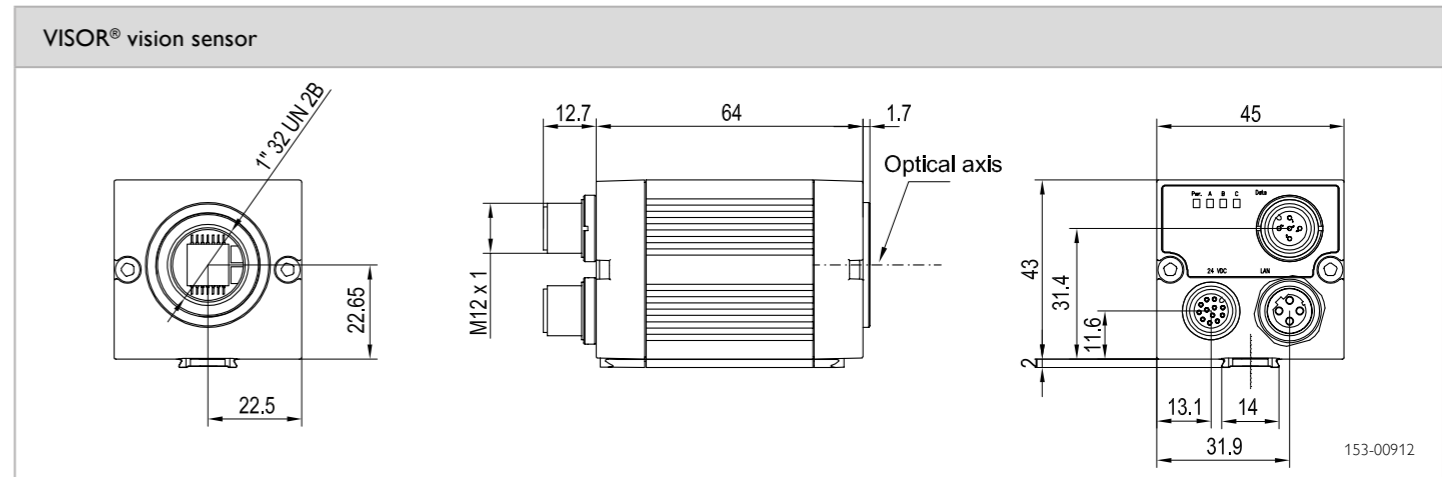

	LO C 8	LO C 12	LO C 16	LO C 25	LO C 35	LO C 50	LO C 75
Focal length	8 mm	12 mm	16 mm	25 mm	35 mm	50 mm	75 mm
Article number	526-51513	526-51514	526-51515	526-51516	526-51525	526-51113	526-51116

Accessories	
Connection cables	From Page A-32
Illumination	From Page A-25
Lenses	From Page A-23
Brackets	From Page A-4
Interface accessories	From Page A-36

Standard vision sensor for code reading, 6 mm

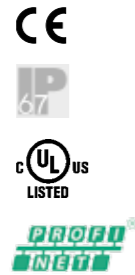

PRODUCT HIGHLIGHTS

- Can be used for all common 2D codes (ECC 200 data matrix) and common 1D bar codes
- Reliable detection of even poorly readable codes under difficult ambient conditions
- Comprehensive tools for flexible and easy connection to PC and PLC environments

VISOR® vision sensor

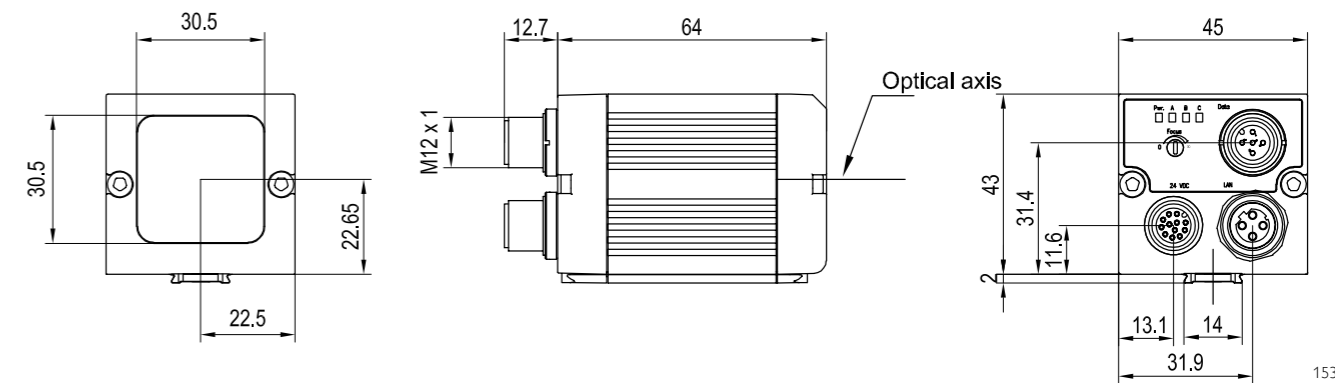

153-00911

Optical data		Functions	
Resolution	736 x 480 pixels	Number of jobs / detectors	8 / 2
CMOS	1/3", monochrome	Detectors	Bar code / data code
Integrated lens, focal length	6 mm, adjustable focal position	Properties	UPC, RSS, 2/5 Interleaved, 2/5 Industrial, Code 39, Code 93, Code 128, GS1, Pharmacode, Codabar; data code: reading of 2D codes, ECC200, QR code, PDF 417
Adjustment range	6 mm to infinity	Typical cycle time	Typ. 30 ms bar code Typ. 40 ms data code
Integrated illumination	White, red, infrared LEDs		
Minimum field of view, X x Y	5 x 4 mm ²		
Electrical data		Mechanical data	
Operating voltage, +U _B	18 ... 26.4 V DC ¹	Dimensions	65 x 45 x 45 mm ³ (without plug)
Current consumption (without illumination and I/O)	≤ 120 mA	Enclosure rating	IP 67
Current consumption (without I/O)	≤ 200 mA	Material, housing	Aluminium, plastic
Protective circuits	Reverse-polarity protection, U _B / short-circuit protection of all outputs	Material, front screen	Plastic
Power On Delay	Ca. 13 s after Power on	Ambient temperature: operation	0 ... +50 °C ²
Outputs	PNP / NPN (switchable)	Ambient temperature: storage	-20 ... +60 °C ²
Max. output current (per output)	50 mA, 100 mA (pin 12)	Weight	Ca. 160 g
Inputs	PNP/NPN High > U _B -1V, Low < 3V	Plug connection	Power and I/O M12, 12pin Ethernet M12, 4pin Data M12, 5-pin
Input resistance	> 20 kOhm	Vibration and impact resistance	EN 60947-5-2
Interfaces	Ethernet (LAN), RS422, RS232, EtherNet/IP, PROFINET		
Inputs/outputs	2 inputs, 4 outputs, 2 selectable inputs/outputs		

¹ Max. ripple < 5 V_{SS} ² 80 % air humidity, non-condensing

Field of view

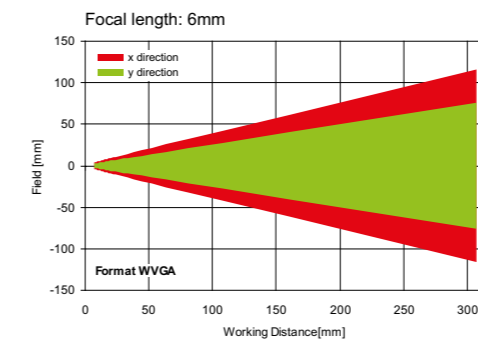

155-01422

Depth of field: normal

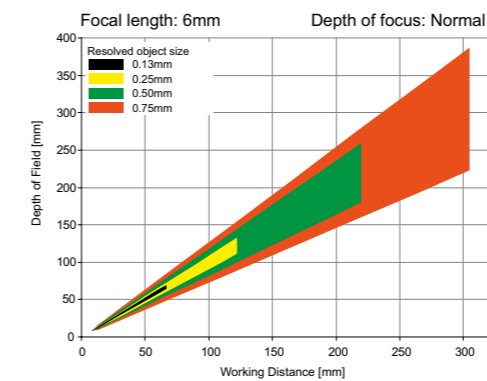

155-01409

Depth of field: enhanced

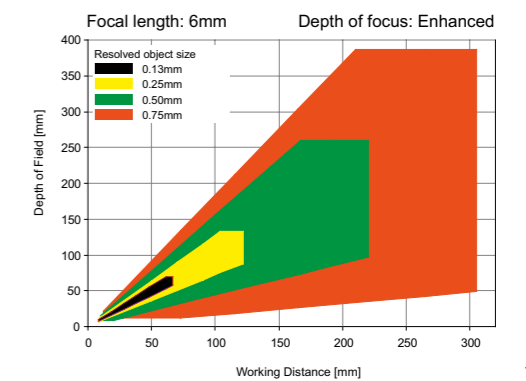

155-01421

Illumination	Depth of field	Part number	Article number
White	Normal	V10-CR-S1-W6	535-91034
White	Enhanced	V10-CR-S1-W6D	535-91036
Red	Normal	V10-CR-S1-R6	535-91038
Red	Enhanced	V10-CR-S1-R6D	535-91040
Infrared	Normal	V10-CR-S1-I6	535-91042
Infrared	Enhanced	V10-CR-S1-I6D	535-91044

Accessories

Connection cables	From Page A-32
Illumination	From Page A-25
Brackets	From Page A-4
Interface accessories	From Page A-36

VISOR® V10 Code Reader

Standard vision sensor for code reading, 12 mm

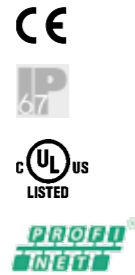

PRODUCT HIGHLIGHTS

- Can be used for all common 2D codes (ECC 200 data matrix) and common 1D bar codes
- Reliable detection of even poorly readable codes under difficult ambient conditions
- Comprehensive tools for flexible and easy connection to PC and PLC environments

VISOR® vision sensor

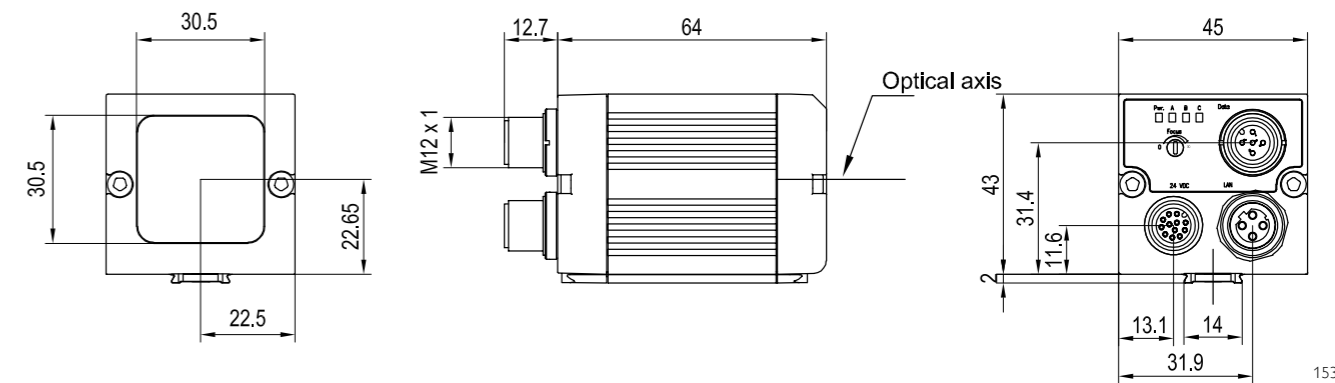

153-00911

Optical data		Functions	
Resolution	736 x 480 pixels	Number of jobs / detectors	8 / 2
CMOS	1/3", monochrome	Detectors	Bar code / data code
Integrated lens, focal length	12 mm, adjustable focal position	Properties	Bar code: reading of 1D bar codes, EAN, UPC, RSS, 2/5 Interleaved, 2/5 Industrial, Code 39, Code 93, Code 128, GS1, Pharmacode, Codabar; data code: reading of 2D codes, ECC200, QR code, PDF 417
Adjustment range	30 mm to infinity	Typical cycle time	Typ. 30 ms bar code Typ. 40 ms data code
Integrated illumination	White, red, infrared LEDs		
Minimum field of view, X x Y	8 x 6 mm ²		
Electrical data		Mechanical data	
Operating voltage, +U _B	18 ... 26.4V DC ¹	Dimensions	65 x 45 x 45 mm ³ (without plug)
Current consumption (without illumination and I/O)	≤ 120 mA	Enclosure rating	IP 67
Current consumption (without I/O)	≤ 200 mA	Material, housing	Aluminium, plastic
Protective circuits	Reverse-polarity protection, U _B / short-circuit protection of all outputs	Material, front screen	Plastic
Power On Delay	Ca. 13 s after Power on	Ambient temperature: operation	0 ... +50 °C ²
Outputs	PNP / NPN (switchable)	Ambient temperature: storage	-20 ... +60 °C ²
Max. output current (per output)	50 mA, 100 mA (pin 12)	Weight	Ca. 160 g
Inputs	PNP/NPN High > U _B -1V, Low < 3V	Plug connection	Supply and I/O M12, 12-pin Ethernet M12, 4-pin Data M12, 5-pin
Input resistance	> 20 kOhm	Vibration and impact resistance	EN 60947-5-2
Interfaces	Ethernet (LAN), RS422, RS232, EtherNet/IP, PROFINET		
Inputs/outputs	2 inputs, 4 outputs, 2 selectable inputs/outputs		

¹ Max. ripple < 5V_{SS} ² 80 % air humidity, non-condensing

Field of view

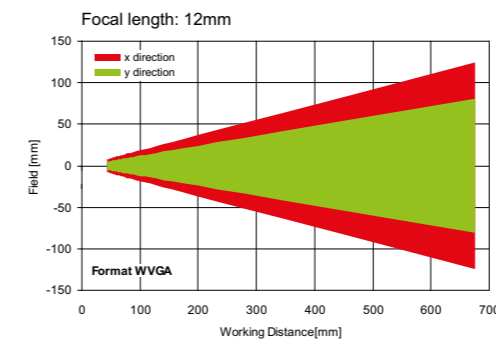

155-01423

Depth of field: normal

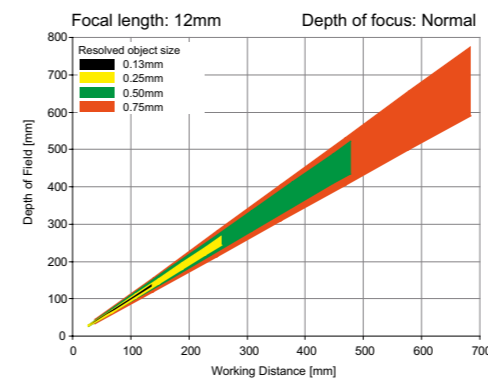

155-01410

Depth of field: enhanced

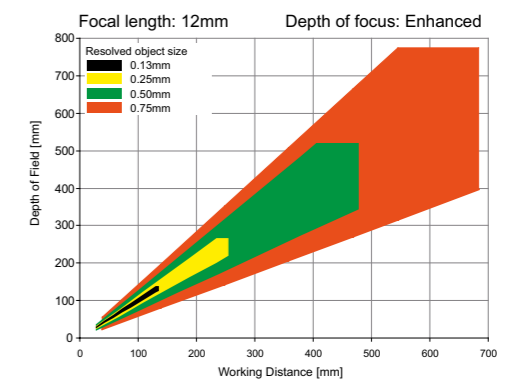

155-01411

Illumination	Depth of field	Part number	Article number
White	Normal	V10-CR-S1-W12	535-91035
White	Enhanced	V10-CR-S1-W12D	535-91037
Red	Normal	V10-CR-S1-R12	535-91039
Red	Enhanced	V10-CR-S1-R12D	535-91041
Infrared	Normal	V10-CR-S1-I12	535-91043
Infrared	Enhanced	V10-CR-S1-I12D	535-91045

Accessories

Connection cables	From Page A-32
Illumination	From Page A-25
Brackets	From Page A-4
Interface accessories	From Page A-36

Standard vision sensor for code reading, 25 mm

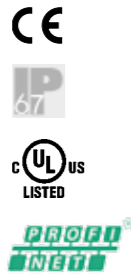

PRODUCT HIGHLIGHTS

- Can be used for all common 2D codes (ECC 200 data matrix) and common 1D bar codes
- Reliable detection of even poorly readable codes under difficult ambient conditions
- Comprehensive tools for flexible and easy connection to PC and PLC environments

VISOR® vision sensor

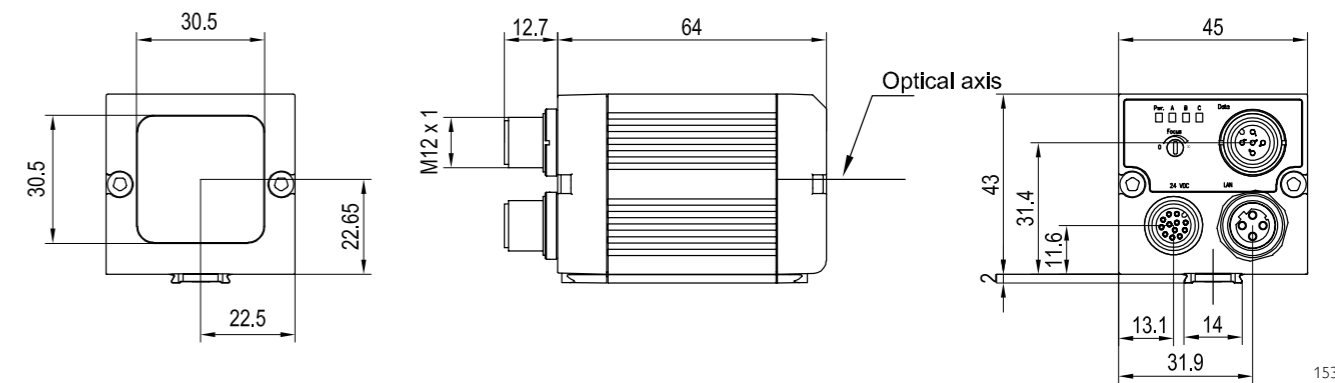

Optical data		Functions	
Resolution	736 x 480 pixels	Number of jobs / detectors	8 / 2
CMOS	1/3", monochrome	Detectors	Bar code / data code
Integrated lens, focal length	25 mm, adjustable focal position	Properties	Bar code: reading of 1D bar codes, EAN, UPC, RSS, 2/5 Interleaved, 2/5 Industrial, Code 39, Code 93, Code 128, GS1, Pharmacode, Codabar; data code: reading of 2D codes, ECC200, QR code, PDF 417
Adjustment range	140 mm to infinity	Typical cycle times	Typ. 30 ms bar code Typ. 40 ms data code
Integrated illumination	White, red, infrared LEDs		
Minimum field of view, X x Y	18 x 14 mm ²		
Electrical data		Mechanical data	
Operating voltage, +U _b	18 ... 26.4V DC ¹	Dimensions	65 x 45 x 45 mm ³ (without plug)
Current consumption (without illumination and I/O)	≤ 120 mA	Enclosure rating	IP 67
Current consumption (without I/O)	≤ 200 mA	Material, housing	Aluminium, plastic
Protective circuits	Reverse-polarity protection, U _b / short-circuit protection of all outputs	Material, front screen	Plastic
Power On Delay	Ca. 13 s after Power on	Ambient temperature: operation	0 ... +50 °C ²
Outputs	PNP / NPN (switchable)	Ambient temperature: storage	-20 ... +60 °C ²
Max. output current (per output)	50 mA, 100 mA (pin 12)	Weight	Ca. 160 g
Inputs	PNP/NPN High > U _b -1V, Low < 3V	Plug connections	Supply and I/O M12, 12-pin Ethernet M12, 4-pin Data M12, 5-pin
Input resistance	> 20 kOhm	Vibration and impact resistance	EN 60947-5-2
Encoder input	High > 4V		
Interfaces	Ethernet (LAN), RS422, RS232, EtherNet/IP, PROFINET		
Inputs/outputs	2 inputs, 4 outputs, 4 selectable inputs/outputs		

¹ Max. ripple < 5V_{SS} ² 80 % air humidity, non-condensing

Illumination	Depth of field	Part number	Article number
White	Normal	V10-CR-S2-W25	535-91088
Red	Normal	V10-CR-S2-R25	535-91089
Infrared	Normal	V10-CR-S2-I25	535-91090

Field of view

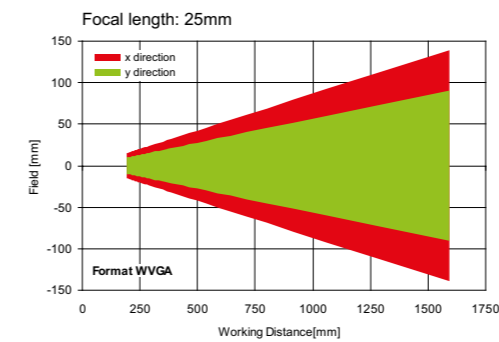

155-01424

Depth of field: normal

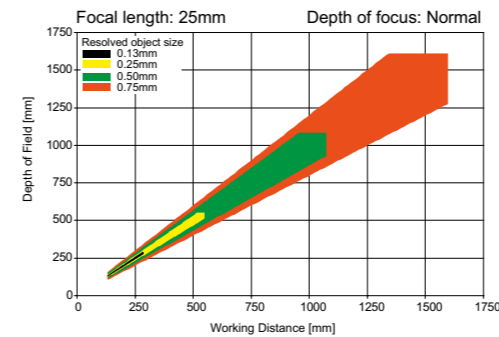

155-01412

Accessories

Connection cables	From Page A-32
Illumination	From Page A-25
Brackets	From Page A-4
Interface accessories	From Page A-36

Advanced vision sensor for code reading with object detection, 6 mm



PRODUCT HIGHLIGHTS

- Can be used for all common 2D codes (ECC 200 data matrix) and common 1D bar codes
- Combination of two functions in one device: code reading and object detection
- Reliable detection of even poorly readable codes under difficult ambient conditions
- Comprehensive tools for flexible and easy connection to PC and PLC environments
- Reading of several similar or differing types of codes in one reading pass

Optical data		Functions	
Resolution	736 x 480 pixels	Number of jobs / detectors	max. 255 / max. 255
CMOS	1/3", monochrome	Detectors	Pattern comparison, contrast, brightness, grey level, bar code, data code
Integrated lens, focal length	6 mm, adjustable focal position	Properties	X/Y position tracking; pattern comparison: teach-in and pattern detection; grey level, brightness: evaluation of brightness; contrast: evaluation of contrasts; bar code: reading of 1D bar codes, EAN, UPC, RSS, 2/5 Interleaved, 2/5 Industrial, Code 39, Code 93, Code 128, GS1, Pharmacode, Codabar; data code: reading of 2D codes, ECC200, QR code, PDF 417
Adjustment range	6 mm to infinity	Typical cycle time	Typ. 20 ms pattern comparison; typ. 2 ms brightness; typ. 2 ms contrast; typ. 2 ms grey level; typ. 30 ms bar code; typ. 40 ms data code
Integrated illumination	White, red, infrared LEDs		
Minimum field of view, X x Y	5 x 4 mm ²		
Electrical data		Mechanical data	
Operating voltage, +U _B	18 ... 26.4 V DC ¹	Dimensions	65 x 45 x 45 mm ³ (without plug)
Current consumption (without illumination and I/O)	≤ 120 mA	Enclosure rating	IP 67
Current consumption (without I/O)	≤ 200 mA	Material, housing	Aluminium, plastic
Protective circuits	Reverse-polarity protection, U _B / short-circuit protection of all outputs	Material, front screen	Plastic
Power On Delay	Ca. 13 s after Power on	Ambient temperature: operation	0 ... +50 °C ²
Outputs	PNP / NPN (switchable)	Ambient temperature: storage	-20 ... +60 °C ²
Max. output current (per output)	50 mA, 100 mA (pin 12)	Weight	Ca. 160 g
Inputs	PNP/NPN High > U _B -1 V, Low < 3 V	Plug connection	Supply and I/O M12, 12-pin Ethernet M12, 4-pin Data M12, 5-pin
Input resistance	> 20 kOhm	Vibration and impact resistance	EN 60947-5-2
Encoder input	High > 4 V		
Interfaces	Ethernet (LAN), RS422, RS232, EtherNet/IP, PROFIBUS		
Inputs/outputs	2 inputs, 4 outputs, 4 selectable inputs/outputs		

¹ Max. ripple < 5V_{SS} ² 80 % air humidity, non-condensing

Illumination	Depth of field	Part number	Article number
White	Normal	V10-CR-A1-W6	535-91021
White	Enhanced	V10-CR-A1-W6D	535-91023
Red	Normal	V10-CR-A1-R6	535-91025
Red	Enhanced	V10-CR-A1-R6D	535-91027

Illumination	Depth of field	Part number	Article number
Infrared	Normal	V10-CR-A1-I6	535-91029
Infrared	Enhanced	V10-CR-A1-I6D	535-91031

VISOR® vision sensor

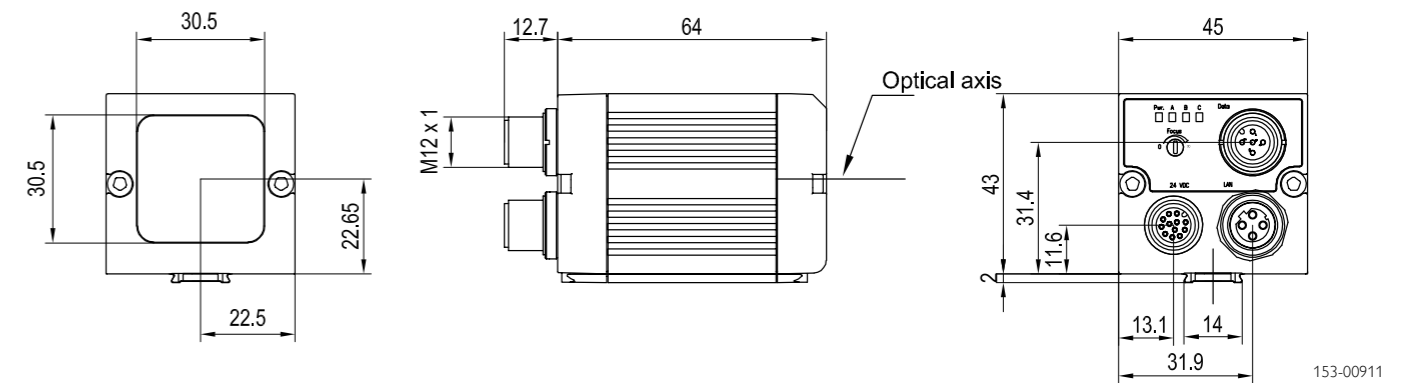

Field of view

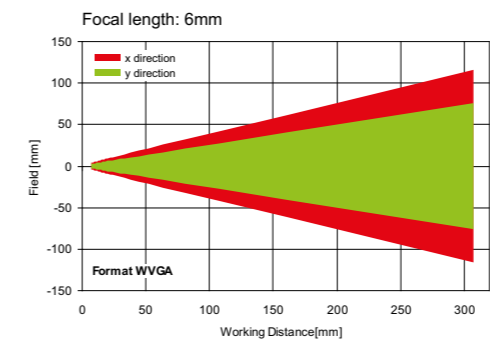

Depth of field: normal

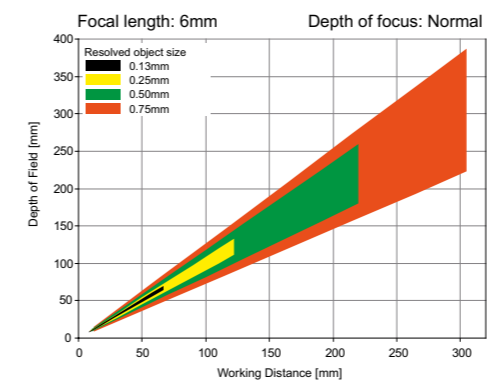

Depth of field: enhanced

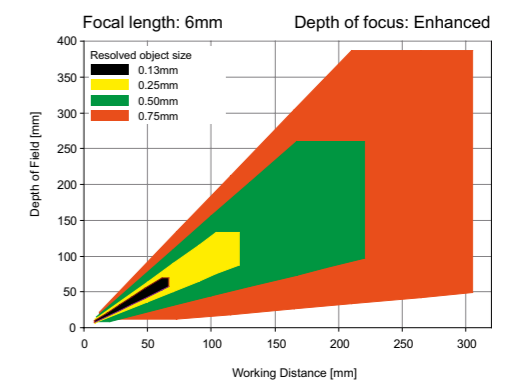

Accessories

Connection cables	From Page A-32
Illumination	From Page A-25
Brackets	From Page A-4
Interface accessories	From Page A-36

Advanced vision sensor for code reading with object detection, 12 mm

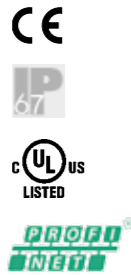

PRODUCT HIGHLIGHTS

- Can be used for all common 2D codes (ECC 200 data matrix) and common 1D bar codes
- Combination of two functions in one device: code reading and object detection
- Reliable detection of even poorly readable codes under difficult ambient conditions
- Comprehensive tools for flexible and easy connection to PC and PLC environments
- Reading of several similar or differing types of codes in one reading pass

Optical data		Functions	
Resolution	736 x 480 pixels	Number of jobs / detectors	max. 255 / max. 255
CMOS	1/3", monochrome	Detectors	Pattern comparison, contrast, brightness, grey level, bar code, data code
Integrated lens, focal length	12 mm, adjustable focal position	Properties	X/Y position tracking; pattern comparison: teach-in and pattern detection; grey level, brightness: evaluation of brightness; contrast: evaluation of contrast; bar code: reading of 1D bar codes, EAN, UPC, RSS, 2/5 Interleaved, 2/5 Industrial, Code 39, Code 93, Code 128, GS1, Pharmacode, Codabar; data code: reading of 2D codes: ECC200, QR code, PDF 417
Adjustment range	30 mm to infinity	Typical cycle time	Typ. 20 ms pattern comparison; typ. 2 ms brightness; typ. 2 ms contrast; typ. 2 ms grey level; typ. 30 ms bar code; typ. 40 ms data code
Integrated illumination	White, red, infrared LEDs		
Minimum field of view, X x Y	8 x 6 mm ²		
Electrical data		Mechanical data	
Operating voltage, +U _B	18 ... 26.4 V DC ¹	Dimensions	65 x 45 x 45 mm ³ (without plug)
Current consumption (without illumination and I/O)	≤ 120 mA	Enclosure rating	IP 67
Current consumption (without I/O)	≤ 200 mA	Material, housing	Aluminium, plastic
Protective circuits	Reverse-polarity protection, U _B / short-circuit protection of all outputs	Material, front screen	Plastic
Power On Delay	Ca. 13 s after Power on	Ambient temperature: operation	0 ... +50 °C ²
Outputs	PNP / NPN (switchable)	Ambient temperature: storage	-20 ... +60 °C ²
Max. output current (per output)	50 mA, 100 mA (pin 12)	Weight	Ca. 160 g
Inputs	PNP/NPN High > U _B -1V, Low < 3V	Plug connection	Supply and I/O M12, 12-pin Ethernet M12, 4-pin Data M12, 5-pin
Input resistance	> 20 kOhm	Vibration and impact resistance	EN 60947-5-2
Encoder input	High > 4V		
Interfaces	Ethernet (LAN), RS422, RS232 EtherNet/IP, PROFINET		
Inputs/outputs	2 inputs, 4 outputs, 4 selectable inputs/outputs		

¹ Max. ripple < 5V_{SS} ² 80 % air humidity, non-condensing

Illumination	Depth of field	Part number	Article number
White	Normal	V10-CR-A1-W12	535-91022
White	Enhanced	V10-CR-A1-W12D	535-91024
Red	Normal	V10-CR-A1-R12	535-91026
Red	Enhanced	V10-CR-A1-R12D	535-91028

Illumination	Depth of field	Part number	Article number
Infrared	Normal	V10-CR-A1-I12	535-91030
Infrared	Enhanced	V10-CR-A1-I12D	535-91032

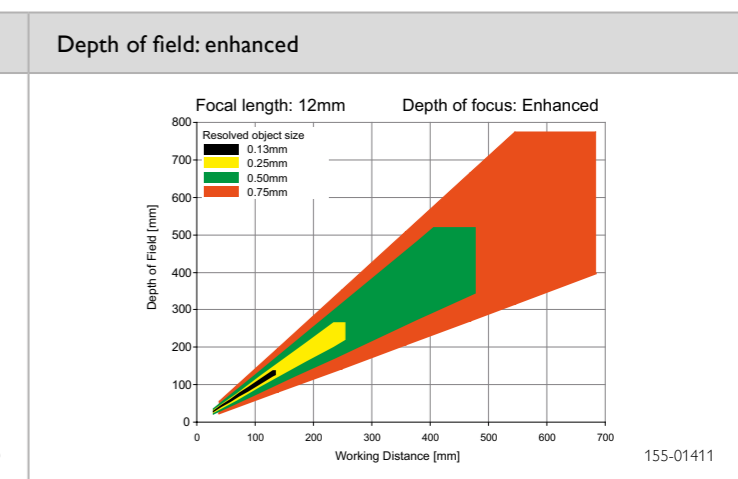
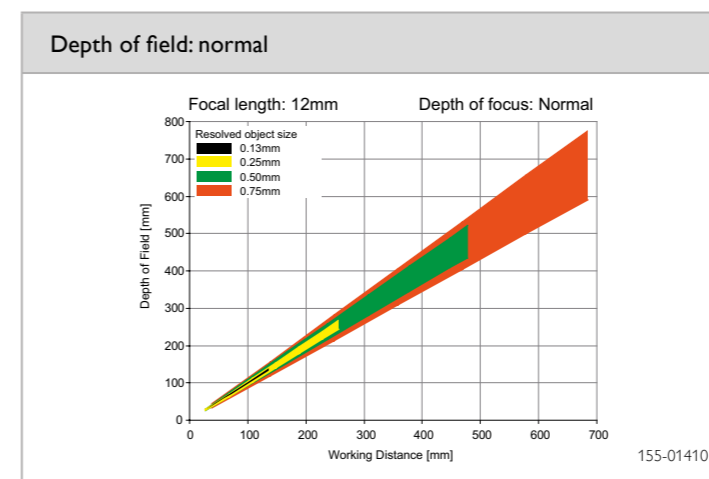
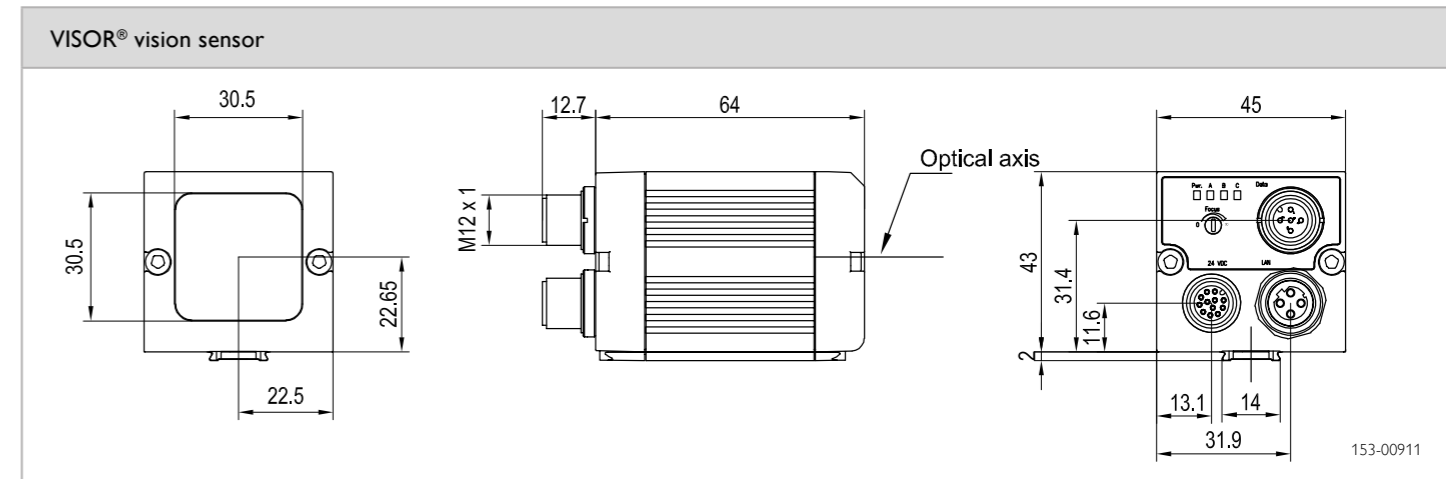

Accessories

Connection cables	From Page A-32
Illumination	From Page A-25
Brackets	From Page A-4
Interface accessories	From Page A-36

Advanced vision sensor code reading with object detection, 25 mm



PRODUCT HIGHLIGHTS

- Can be used for all common 2D codes (ECC 200 data matrix) and common 1D bar codes
- Combination of two functions in one device: code reading and object detection
- Reliable detection of even poorly readable codes under difficult ambient conditions
- Comprehensive tools for flexible and easy connection to PC and PLC environments
- Reading of several similar or differing types of codes in one reading pass

Optical data		Functions	
Resolution	736 x 480 pixels	Number of jobs / detectors	max. 255 / max. 255
CMOS	1/3", monochrome	Detectors	Pattern comparison, contrast, brightness, grey level, bar code, data code
Integrated lens, focal length	25 mm, adjustable focal position	Properties	X/Y position tracking; pattern comparison: teach-in and pattern detection; grey level, brightness: evaluation of brightness; contrast: evaluation of contrast; bar code: reading of 1D bar codes, EAN, UPC, RSS, 2/5 Interleaved, 2/5 Industrial, Code 39, Code 93, Code 128, GS1, Pharmacode, Codabar; data code: reading of 2D codes: ECC200, QR code, PDF 417
Adjustment range	140 mm to infinity		
Integrated illumination	White, red, infrared LEDs		
Minimum field of view, X x Y	18 x 14 mm ²	Typical cycle times	Typ. 20 ms pattern comparison; typ. 2 ms brightness; typ. 2 ms contrast; typ. 2 ms grey level; typ. 30 ms bar code; typ. 40 ms data code
Electrical data		Mechanical data	
Operating voltage, +U _b	18 ... 26.4V DC ¹	Dimensions	65 x 45 x 45 mm ³ (without plug)
Current consumption (without illumination and I/O)	≤ 120 mA	Enclosure rating	IP 67
Current consumption (without I/O)	≤ 200 mA	Material, housing	Aluminium, plastic
Protective circuits	Reverse-polarity protection, U _b / short-circuit protection of all outputs	Material, front screen	Plastic
Power On Delay	Ca. 13 s after Power on	Ambient temperature: operation	0 ... +50 °C ²
Outputs	PNP / NPN (switchable)	Ambient temperature: storage	-20 ... +60 °C ²
Max. output current (per output)	50 mA, 100 mA (pin 12)	Weight	Ca. 160 g
Inputs	PNP/NPN High > U _b -1V, Low < 3V	Plug connections	Supply and I/O M12, 12-pin Ethernet M12, 4-pin Data M12, 5-pin
Input resistance	> 20 kOhm	Vibration and impact resistance	EN 60947-5-2
Encoder input	High > 4V		
Interfaces	Ethernet (LAN), RS422, RS232, EtherNet/IP, PROFINET		
Inputs/outputs	2 inputs, 4 outputs, 4 selectable inputs/outputs		

¹ Max. ripple < 5V_{SS} ² 80 % air humidity, non-condensing

Illumination	Depth of field	Part number	Article number
White	Normal	V10-CR-A2-VW25	535-91084
Red	Normal	V10-CR-A2-R25	535-91085
Infrared	Normal	V10-CR-A2-I25	535-91086

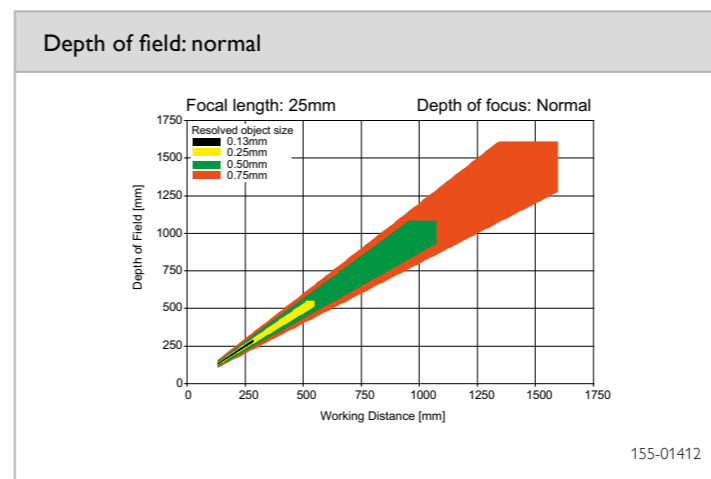
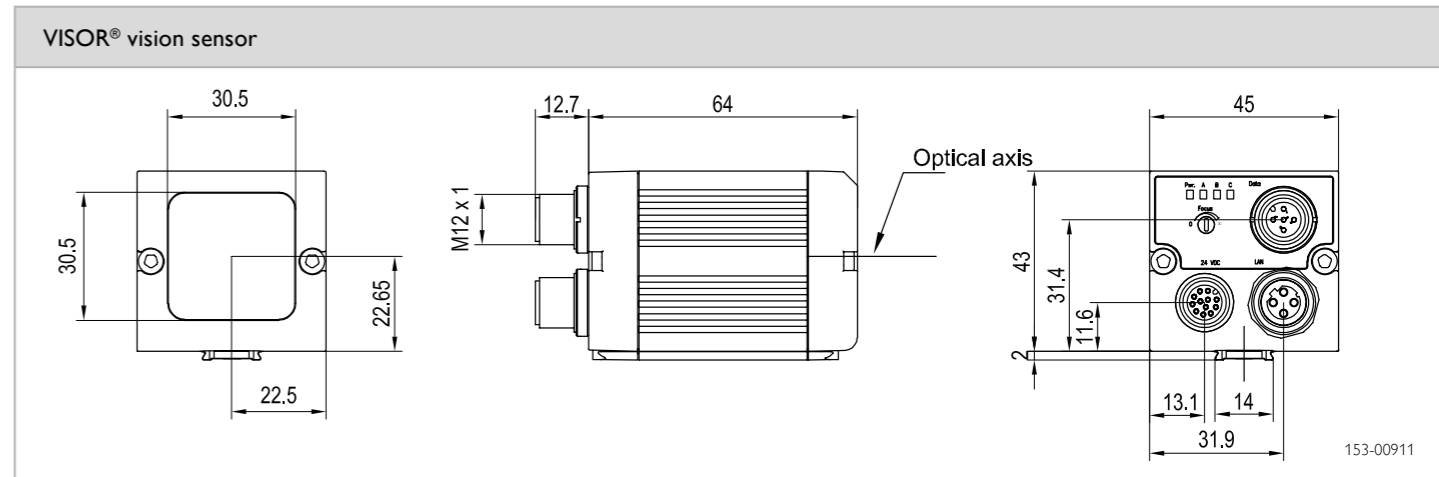

Accessories	
Connection cables	From Page A-32
Illumination	From Page A-25
Brackets	From Page A-4
Interface accessories	From Page A-36

Advanced vision sensor for code reading with object detection, C-mount



PRODUCT HIGHLIGHTS

- Can be used for all common 2D codes (ECC 200 data matrix) and common 1D bar codes
- Combination of two functions in one device: code reading and object detection
- Reliable detection of even poorly readable codes under difficult ambient conditions
- Comprehensive tools for flexible and easy connection to PC and PLC environments
- Reading of several similar or differing types of codes in one reading pass

Optical data		Functions	
Resolution	736 x 480 pixels	Number of jobs / detectors	max. 255 / max. 255
CMOS	1/3", monochrome	Detectors	Pattern comparison, contrast, brightness, grey level, bar code, data code
Integrated lens, focal length	C-mount	Properties	X/Y position tracking; pattern comparison: teach-in and pattern detection; grey level, brightness: evaluation of brightness; contrast: evaluation of contrast; bar code: reading of 1D bar codes, EAN, UPC, RSS, 2/5 Interleaved, 2/5 Industrial, Code 39, Code 93, Code 128, GS1, Pharmacode, Codabar; data code: reading of 2D codes: ECC200, QR code, PDF 417
Adjustment range	Dependent on lens	Typical cycle time	Typ. 20 ms pattern comparison; typ. 2 ms brightness; typ. 2 ms contrast; typ. 2 ms grey level; typ. 30 ms bar code; typ. 40 ms data code
Integrated illumination	None		
Minimum field of view, X x Y	Dependent on lens		
Electrical data		Mechanical data	
Operating voltage, +U _B	18 ... 26.4 V DC ¹	Dimensions	65 x 45 x 45 mm ³ (without plug)
Current consumption (without illumination and I/O)	≤ 120 mA	Enclosure rating	IP 65 ²
Current consumption (without I/O)	≤ 200 mA	Material, housing	Aluminium, plastic
Protective circuits	Reverse-polarity protection, U _B / short-circuit protection of all outputs	Material, front screen	Plastic
Power On Delay	Ca. 13 s after Power on	Ambient temperature: operation	0 ... +50 °C ³
Outputs	PNP / NPN (switchable)	Ambient temperature: storage	-20 ... +60 °C ³
Max. output current (per output)	50 mA, 100 mA (pin 12)	Weight	Ca. 160 g
Inputs	PNP/NPN High > U _B -1 V, Low < 3 V	Plug connection	Supply and I/O M12, 12-pin Ethernet M12, 4-pin Data M12, 5-pin
Input resistance	> 20 kOhm	Vibration and impact resistance	EN 60947-5-2
Encoder input	High > 4 V		
Interfaces	Ethernet (LAN), RS422, RS232 EtherNet/IP, PROFINET		
Inputs/outputs	2 inputs, 4 outputs, 4 selectable inputs/outputs		

¹ Max. ripple < 5V_{SS} ² With LPT45 C-mount protective casing ³ 80 % air humidity, non-condensing

Part number	Article number
V10-CR-A1-C	535-91033

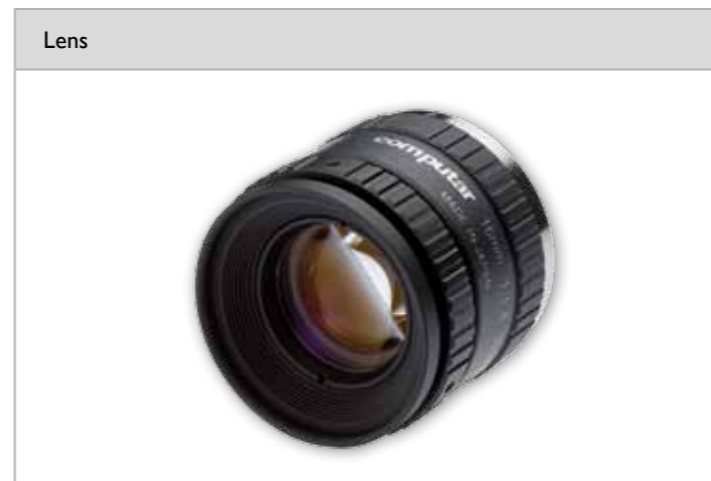
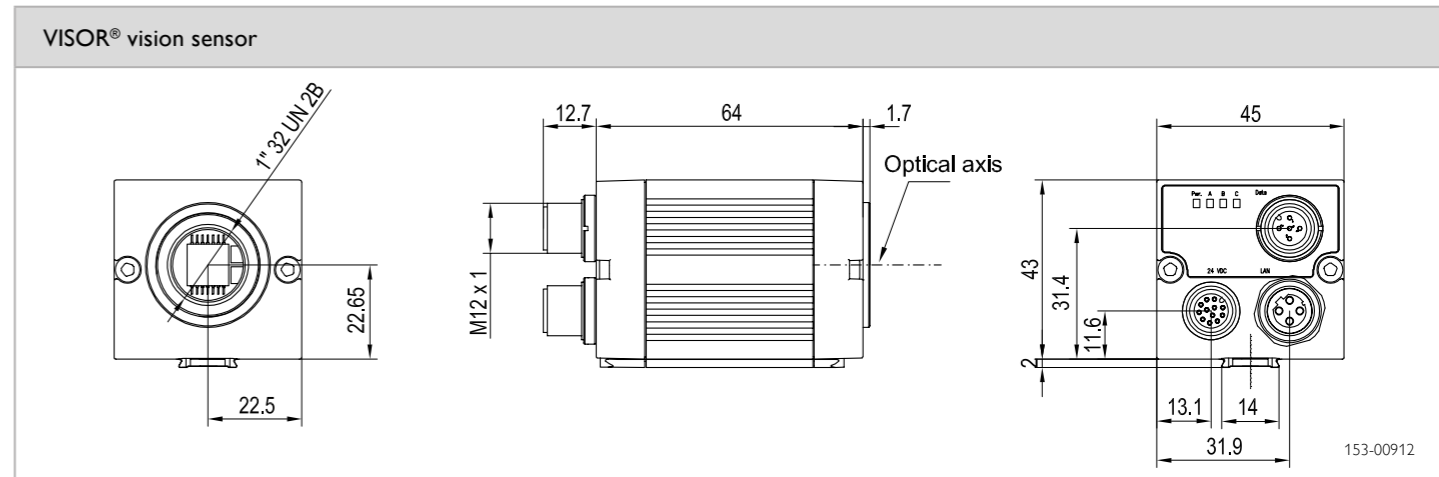

	LO C 8	LO C 12	LO C 16	LO C 25	LO C 35	LO C 50	LO C 75
Focal length	8 mm	12 mm	16 mm	25 mm	35 mm	50 mm	75 mm
Article number	526-51513	526-51514	526-51515	526-51516	526-51525	526-51113	526-51116

Accessories	
Connection cables	From Page A-32
Illumination	From Page A-25
Lenses	From Page A-23
Brackets	From Page A-4
Interface accessories	From Page A-36